

Stair Installation Instructions



2910 Waters Road
Eagan, MN 55121
855-742-7245

Items Required for Installation

- Appropriate fasteners for mounting posts
- Miter saw with carbide-tipped non-ferrous blade
- Cordless drill
- Tape measure
- Level
- Power cords, drop sheets and safety glasses
- #2 Square driver bit

IMPORTANT NOTE!

STAIR PANEL ACTUAL LENGTH:

6' Panels - 69.55"

For the most recent installation instructions, go to our Website at www.ultralox.com

Prior to construction, check with your local regulatory agency for special code requirement in your area. Common residential stair railing height is 36". ADA secondary grabrail may be necessary to meet local code compliance. Stair post spans should never exceed 6' on center. For all other applications, consult a design professional or an UltraLox representative for more information.

Read installation instructions thoroughly before proceeding with assembly.

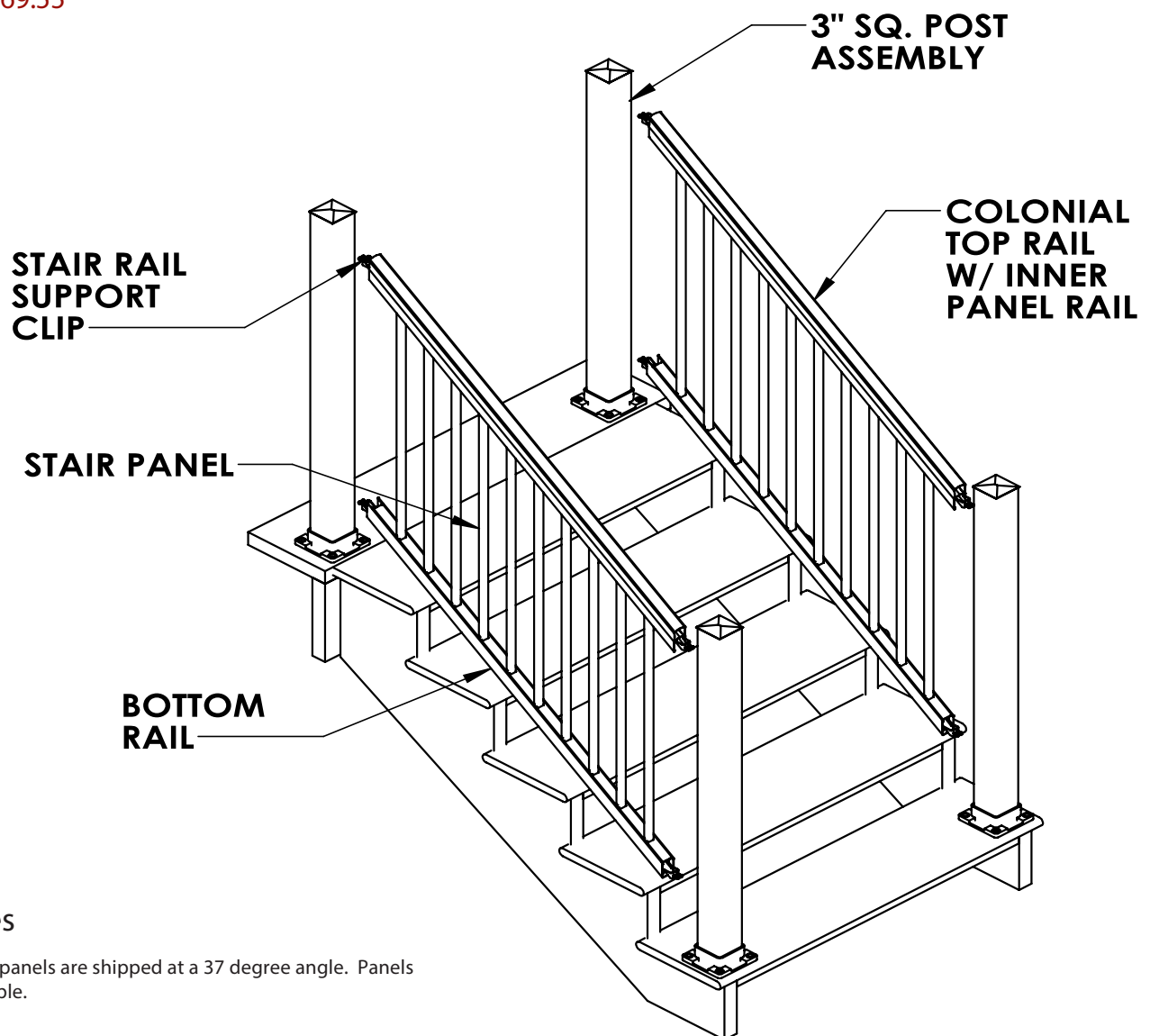

Key Notes

- Stair railing panels are shipped at a 37 degree angle. Panels are adjustable.
- Maximum posts spans on stair railing application is 6' on-center. Additional posts are required on any stair application more than 6 feet in length.
- For all other applications, consult a design professional or an UltraLox representative for more information.

Step 1

Fitting Stair Railing Panel

Position stair railing panel alongside 3" top stair post and temporarily installed 3" bottom post. (Refer to Figure 1).

Position stair panel approximately 1-1/2" above stair nosing. Tip - lay a 2"x4" board flat on nose of stair treads. This will allow enough room for installation of bottom snap. Clamp stair panel against top and bottom 3" posts. Using a sharp #2 pencil, mark the stair channels at four (4) locations.

Remove clamps and cut stair panel at all four (4) locations. (Figure 2) Take care to cut stair channels at appropriate stair angle. Use of Mitre saw with a sharp non-ferrous blade is recommended.

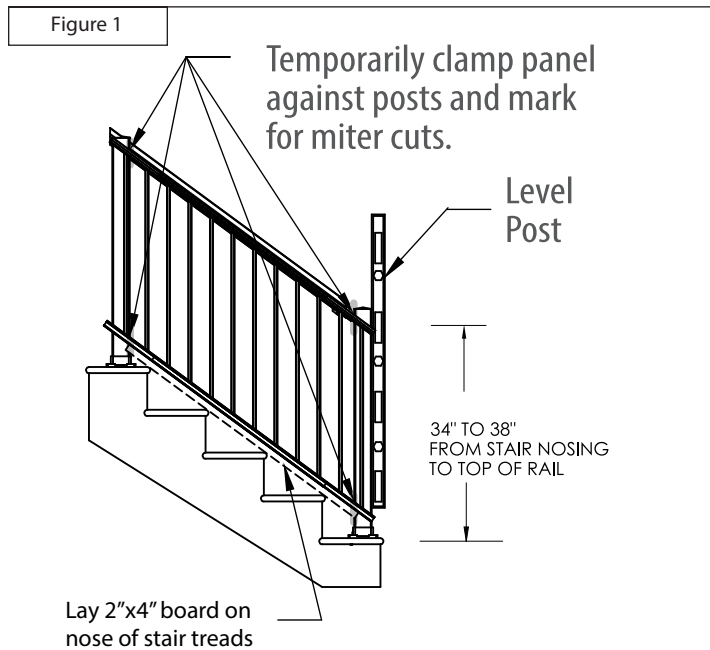

Step 2

Installing Stair Clips on Posts

After stair panel has been cut to proper size and angle, place the panel on the 2"x4" board, between the 3" posts. Use a #2, sharp pencil and draw a line across the top of the lower picket channel, 2 places (Figure 3).

Remove panel and bottom post. Attach stair panel attach clips at marked location as per (Figure 4) and fasten with #8x3/4" Tec Screws.

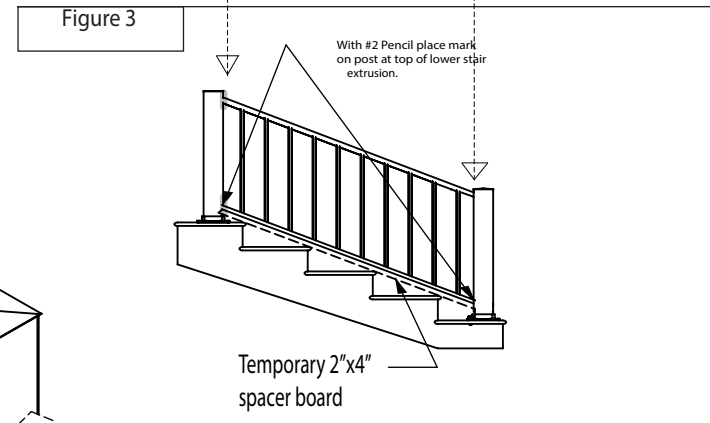
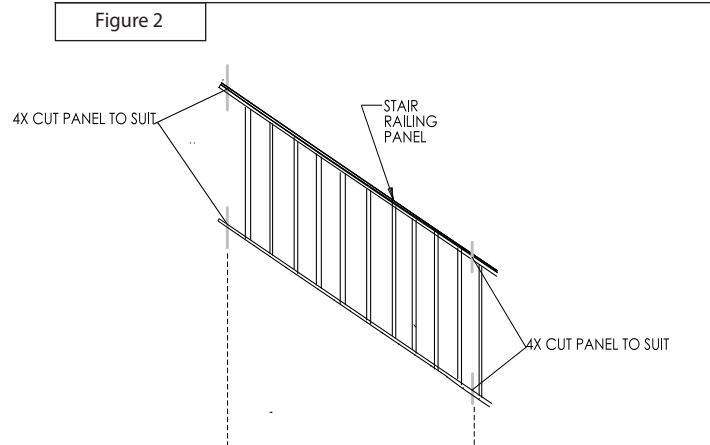
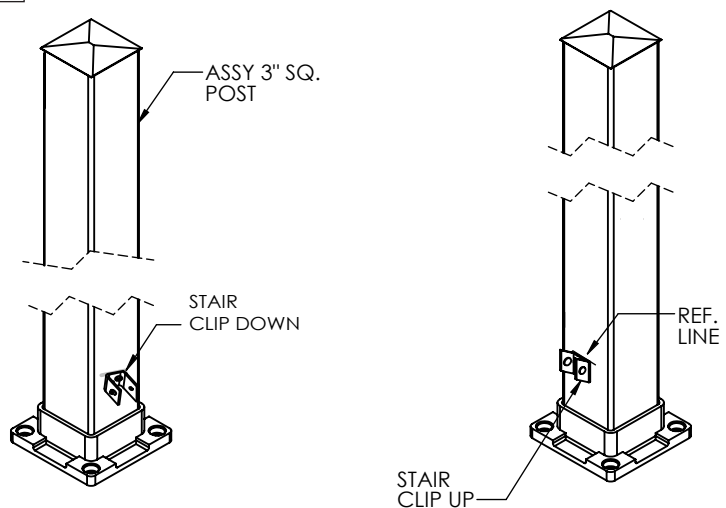

Figure 4



Step 3

Securing Stair Panel to 3" Posts

Once the stair panel attach clips have been installed, re-attach the lower 3" post to the bottom step or landing. Place the stair panel lower extrusion onto the lower stair panel attach clips (Figure 5).

When lower extrusion is securely inserted on lower stair clips (ensure panel is fully seated on to both upper and lower clips), insert stair panel attach clip (start with upper post) into upper extrusion, secure attach clip to post with 2-#8x3/4" Tek Screws, then secure upper extrusion to stair panel attach clip with 2-#8x3/4" Tek Screws. Repeat this same procedure for bottom post upper extrusion (Figure 6).

When upper extrusion is secured to attach clips, return to lower extrusion and secure lower extrusion to lower stair clips with 2-#8x3/4" Tek Screws at upper post and 2-#8x3/4" Tek Screws at lower post.

Figure 5

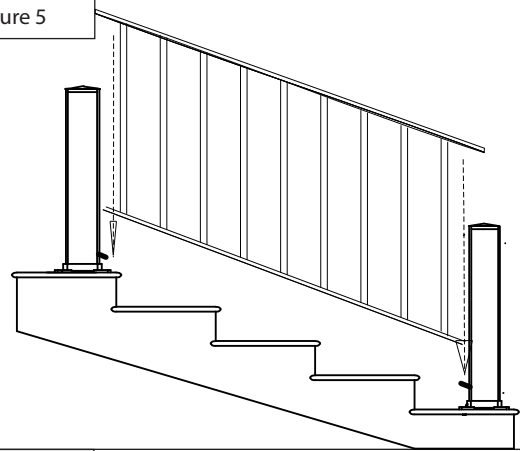
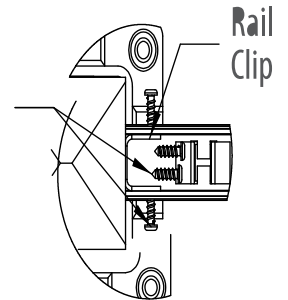

Figure 6

Install, TEK Screws,
2x #8 x 3/4" Outside
2x #8 x 3/4" Inside



Step 4

Install Top and Bottom Snap Covers

Following the same angle as the secured stair panel clamp or hold top/bottom rail snaps against 3" posts (Figure 7). Using a sharp #2 pencil, mark the top/bottom rail snaps at all four (4) locations.

Remove clamps and cut top/bottom rail snaps at all four (4) locations. Take care to cut snaps at appropriate stair angle. Use of Mitre saw with a sharp non-ferrous blade is recommended.

Clean cut areas and apply touch-up paint on exposed ends.

Snap each rail snap over the corresponding rail channel until properly seated (Figure 8).

Figure 7

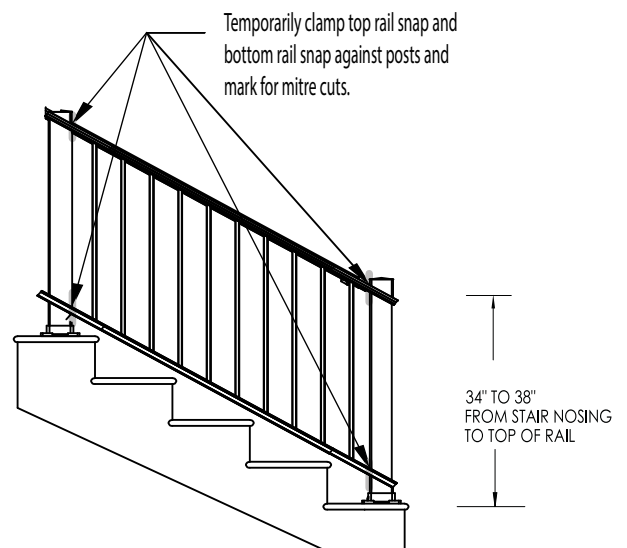
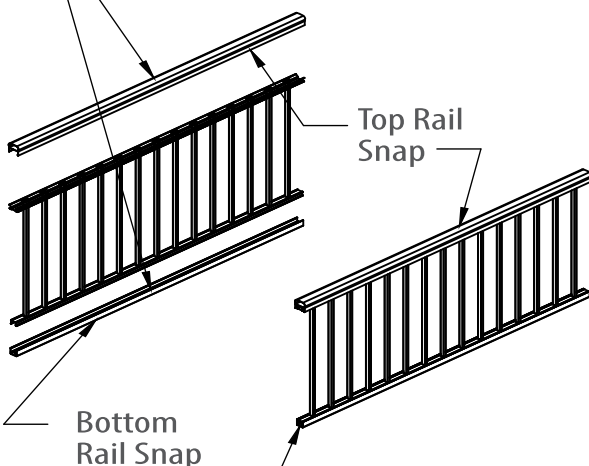

Figure 8

Push top and Bottom rail snap down and up onto panel until properly seated



Step 5

Installation of ADA Compliant Hand Rail

ADA handrail may be required (Figure 9) for residential deck installations (check with local building code official).

Maximum recommended span between posts is 6' on center.

See UltraLox ADA Railing Installation Instructions for all installation configurations.

Figure 9

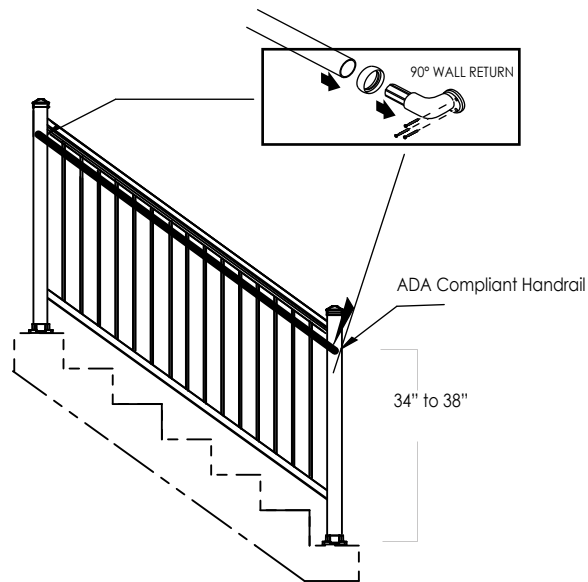

System Evaluation:

1. UltraLox railing products have been evaluated for structural integrity by an independent laboratory as per ICC-ES AC273 - Acceptance Criteria for Handrails and Guards, approved February 2008 and effective March 1, 2008 (editorially revised January 2012). UltraLox's Mission, Colonial and Victorian 42" aluminum railing systems were evaluated with a total railing span of 96" with an UltraLox 3" post attached at each end and secured to a structural wood frame with four GRK RSS 5/16"x3/4" deck structural screws per post. The UltraLox aluminum railing systems have been evaluated with 1/2"x3/4" aluminum balusters (6063-T5) assembled using the patented UltraLox Interlocking assembly process by which guardrail infill components are press locked together. UltraLox's 1/4" tempered glass panel system (ANSI Z97.1 tempered glass) has been evaluated with a total railing span of 72" with an UltraLox heavy wall 1-3/4" post attached at each end and secured to a concrete substrate with 4-ITW Redhead anchors LDT 3824 3/8"x2-1/2". When the guardrail is installed in configuration other than described in the installation instructions, the installation configuration and fastening detail must be specified by a licensed engineer.
2. When UltraLox aluminum railing systems are assembled under the conditions described above, the railing meets the guardrail requirements of 1607.7.1.1 of the 2012 International Building Code (IBC).
3. When UltraLox guardrail is installed in configurations other than described above, each installation shall be designed using numerical methods by a registered professional engineer licensed in the state in which the project is constructed. Sealed shop drawings shall be made available to interested parties to demonstrate compliance with applicable code in which the project is constructed. Sealed shop drawings shall be made available to interested parties.
4. If UltraLox aluminum railings are installed contrary to the specific assembly described above and sealed engineering drawings are not available, then the railing is intended for decorative purposes only and cannot be used in applications where a structural railing system is required by building code.

The diagrams and instructions in this brochure are for illustration purposes only and are not meant to replace a licensed professional. Any construction or use of the product must be in accordance with all local zoning and/or building codes. The consumer assumes all risks and liability associated with the construction or use of this product. The consumer or contractor should take all necessary steps to ensure the safety of everyone involved in the project, including, but not limited to, wearing the appropriate safety equipment. Except as contained in the written limited warranty, UltraLox does not provide any other warranty, either express or implied, and shall not be liable for any damages, including consequential damages.